

Main Features:-

- ◆ Uni-Directional Knife Gate Valve
- ◆ Manually Operated With Lever
- ◆ Wafer Threaded, PN10
- ◆ On/Off or Regulation
- ◆ Direction Indicated By Arrows On The Body

*Temperature and pressure determined by valve body, seat etc.

Suitable Applications & Approvals:



WASTE



INDUSTRY



CERTIFIED



SERIES: 43005

MANUFACTURER: **Tecofi**
VALVE DESIGNER - FRANCE

DN	SIZE	A	B	C	D	H min	H max	I	J	K	L	ØK	n	ØM	Kg
50	2"	40	240	124	83	93	329	140	330	119	140	125	4	4xM16	7.5
65	2 1/2"	40	265	139	83	119	407	140	330	119	140	145	4	4xM16	7.8
80	3"	50	290	154	83	226	563	140	330	119	140	160	8	4xM16	8.4
100	4"	50	335	174	83	147	631	140	430	119	140	180	8	4xM16	11.5
125	5"	50	373	189	93	187	767	140	430	119	140	210	8	4xM16	14.4
150	6"	60	424	220	93	236	918	140	430	119	140	240	8	4xM20	18.5
200	8"	60	533	275	108	183	1058	228	638	173	255	295	8	4xM20	28.8
250	10"	70	625	326	108	321	1374	228	638	173	255	350	12	8xM20	41
300	12"	70	732	380	108	449	1709	228	638	173	255	400	12	8xM20	58

VALVE DIMENSIONS

DIMENSIONAL DRAWING

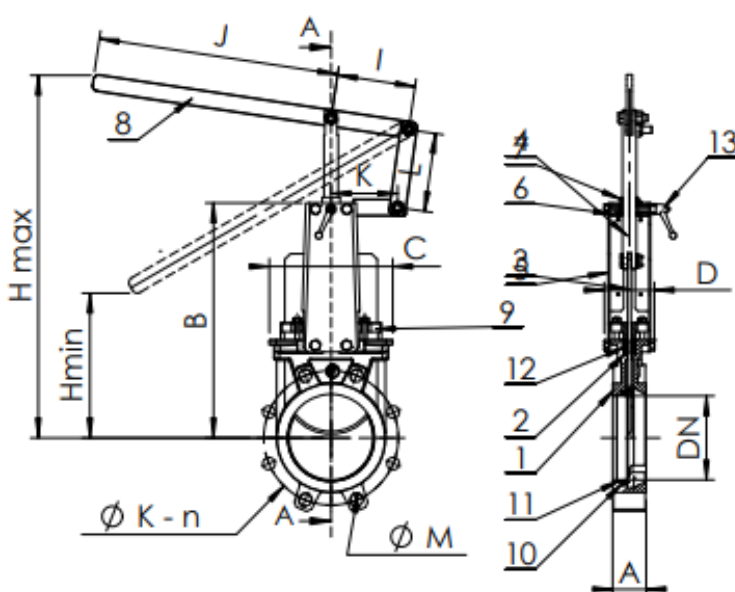

No	Description	Material
1	Body	EN-GJL-250
2	Packing	PTFE
3	Gate	SS X5CrNi 18-10
4	Stem	SS 13%Cr
5	Support Plate	Steel + Epoxy
6	Nut Support	Zinc Steel
7	Guide Ring	Bronze
8	Lever	Steel
9	Packing Gland	Ductile Iron
10	Gasket	Nitrile
11	Supporting Ring	SS 316
12	O'Ring	Nitrile
13	Locked Screw	Coated Steel

T +44 (0)1386 552369

E sales@allvalves.co.uk

W www.allvalves.co.uk

F +44 (0)1386 554227



MANUFACTURER: **Tecofi**
VALVE DESIGNER - FRANCE

SERIES: 43005

Material	Max Working Temperature	DN	Max Working Pressure	TECOFI
Metal/Metal	-10°C / +80°C	DN50-250	10 Bar	<p>The company is based in Lyon for 30 years. French manufacturer of industrial valves, that carry out the design, manufacture and marketing of a complete range of valves for all types of industries. Tecofi are one of the major players in the field of water, climate engineering, paper, chemical, steel and energy industry.</p>
White NBR	-10°C / +80°C	DN300	7 Bar	
EPDM	-10°C / +130°C			
Silicone	-10°C / +170°C			
FPM (Viton)	-10°C / +170°C			
PTFE	+4°C / +170°C			
CSM (Hypalon)	+4°C / +80°C			

ALL VALVES ONLINE

Offering a full range of actuated valve packages, manual valve range, pipe fittings and pumps, we have a product for all your requirements. As an ISO 9001-2015 Quality Approved and certified company, All Valves offer a quality service from pre-sale to post sale. Shipping millions of pounds in value of manual valve and actuated valve packages all over the world since its formation, All Valves are a trusted valve and actuator supplier to many companies all over the world. Working with the leading brands in most industries.

The Tecofi knife gate valve can typically be used for the following applications;

- Pulp and Paper
- Water
- Water Treatment
- Biogas
- Chemical
- Powder
- Slurry and Waste
- Mining

TEMPERATURE AND PRESSURE



T +44 (0)1386 552369

E sales@allvalves.co.uk

W www.allvalves.co.uk

F +44 (0)1386 554227